

ADAM-6022
Dual Loop PID Controller
User's Manual

Warning Message :

The ADAM-6022 is recommended to be used in general purposed air conditioning application. When using this product in applications that required particular safety or when using this product in important facility, pay attention to the safety of the overall system and equipment. For example, install fail-safe mechanism, carry out redundancy checks and periodic inspections, and adopt other appropriate safety measures as required.

ADAM-6022 dual loop PID Controller

Introduction

- Function** The ADAM-6022 dual loop PID controller is a PC-based stand alone controller. It was designed as the product of Advantech's ADAM-6000 series with web-enabled PID controller. With a excellent accuracy $\pm 0.15\%$, the ADAM-6022 is an ideal controller for temperature and other process variable in heating and cooling application, test and environmental work.
- Easy to operate** ADAM-6022 utility software can help you to select input and range configuration, set the operating parameter (SP, Sv, Pv etc) for your process control needed. ADAM-6022 utility software also integrates the trend chart to help you to monitor and debug your control setting.
- Industrial Design** ADAM-6022 was designed to use in industrial environment. It can be installed in standard DIN rail inside the cabinet. And it can be powered by unregulated 10~30Vdc to meet the various power supplied source in field. It also withstands ambient temperature up to 60 ° C and resists the effects of vibration and mechanical shock.

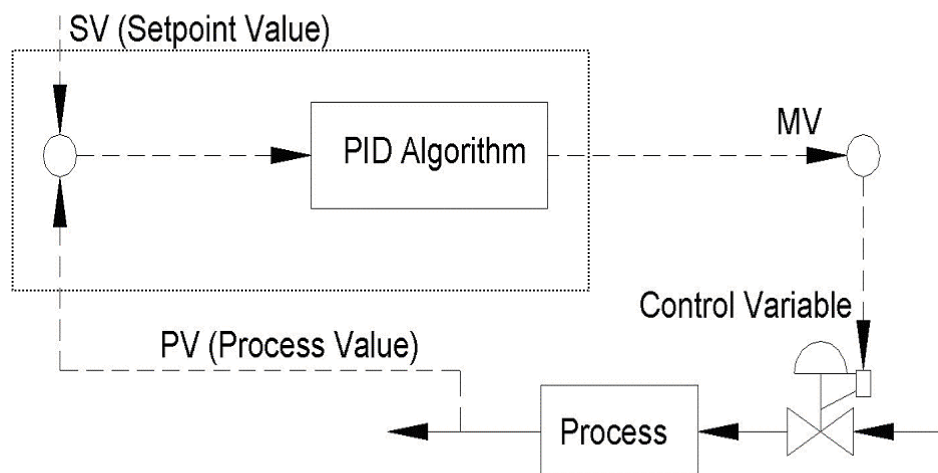

Wiring & Installation

The ADAM-6022 is a 2 loop PID controller. There are three analog input, one analog output, one digital input and one digital out put for each loop usage. The analog input channels is 16-bit, universal signal accepted design. It provides programmable input ranges on all channels. It accepts various analog inputs +/-10V, 0~20mA and 4~20mA. The analog output channel is 12 bit with 0~10V, 0~20mA and 4~20mA acceptable input type. Each analog channel is allowed to configure an individual range for several applications. The digital input can be configured as the emergency shutdown trigger input and the digital output is designed as the common alarm output. The PID loop function can be disabled by ADAM-6022 utility software tool, that is, ADAM-6022 can be a pure universal I/O module after disabling the PID loop function.

ADAM-6022

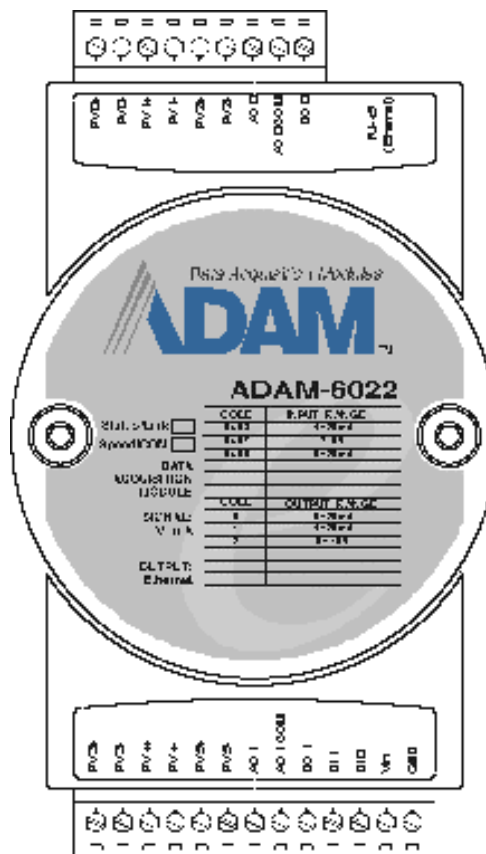

Fig. 7-1 ADAM-6022 Drawing

Application Wiring

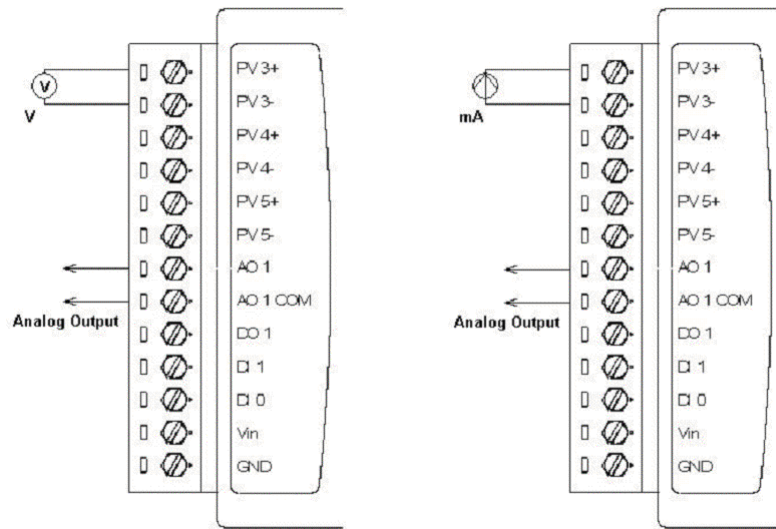

Fig. 7-2 Analog Input/Output Wiring Diagram

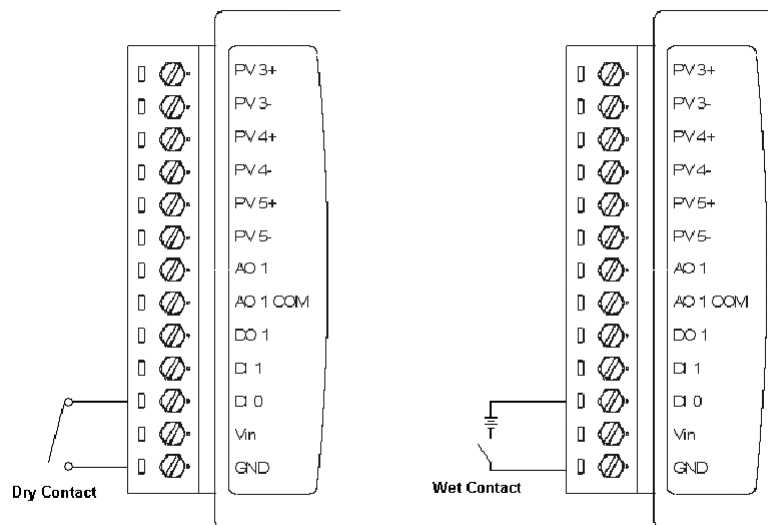

Fig. 7-3 Digital Input Wiring Diagram

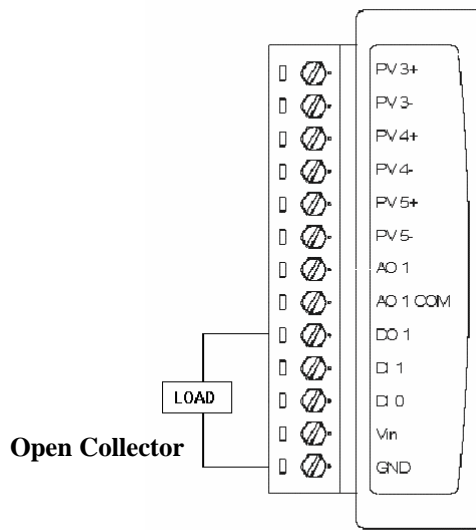

Fig. 7-4 Digital Output Wiring Diagram

Web Server Function

There is a built-in web server on the ADAM-6022 module. Use standard web browser to connect to the web server and see the web page. The website is simply the IP address of the ADAM-6022 module you want to connect. (For example: <http://172.18.3.24>) Before you open the web page, you need to type correct user name and password. Below is the default user name and password. After you type the correct user name and password, you should be able to see the web page and see what's happening on the module.

User name: **root**

Password: **00000000**

Jumper Setting

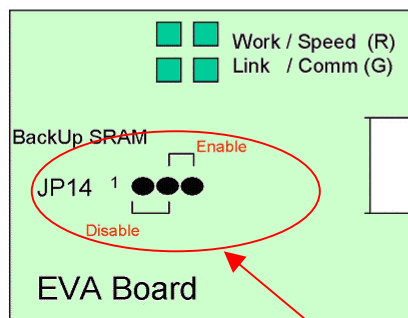
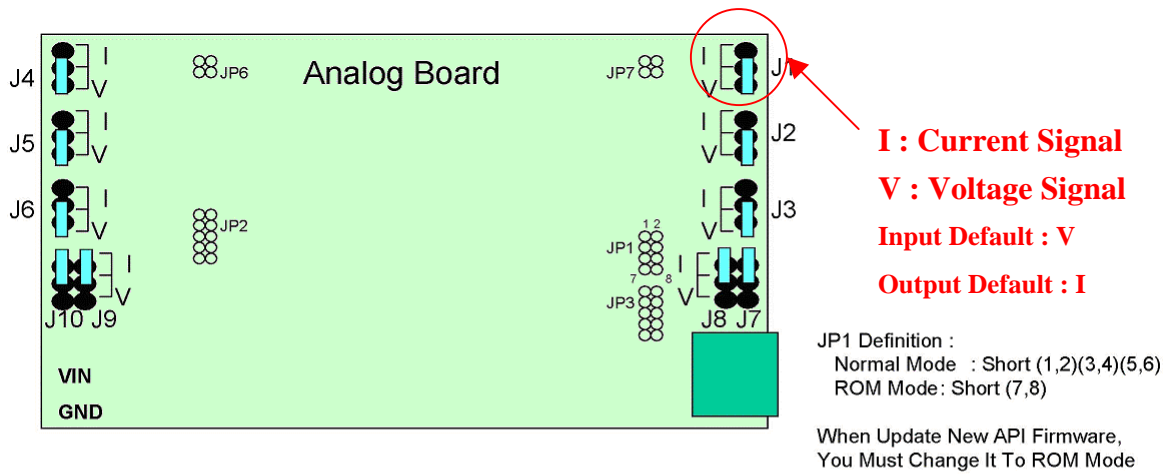

The Backup SRAM jumper default setting is "Disable". Please set the jumper in "Enable" when using ADAM-6022.

Operation Interface

Open the ADAM Ethernet IO Utility Software, the software tool will auto-scan the ADAM Ethernet module through the network. Clicking the “6022” in the system tree of left dialog block,

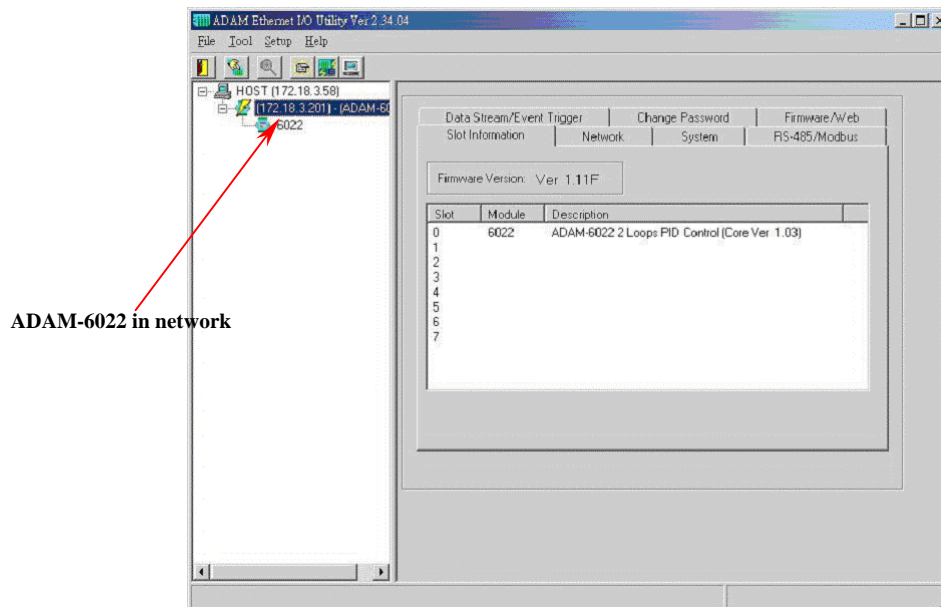

Clicking the “6022” in the system tree of left dialog block to go to ADAM-6022 configuration page. In this page, user can configure the input channel, output channel and PID loop function.

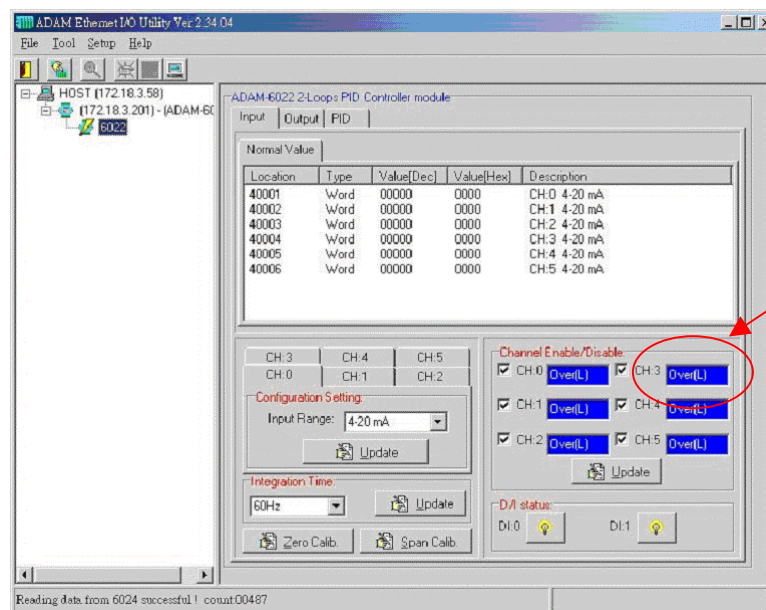

Input Channel Configuration Page :

In ADAM-6022 input channel configuration page, user can enable the input channel, select the input signal type and select the DI status. Channel 0, 1, 2 is the analog input as the control parameter for PID loop 0 and channel 3, 4, 5 is for PID loop 1 when the PID loop function is enabled. ADAM-6022 also support MODBUS/RTU protocol, user can see the detail MODBUS address register number for each channel in this page. It can be a very important reference for communication work.

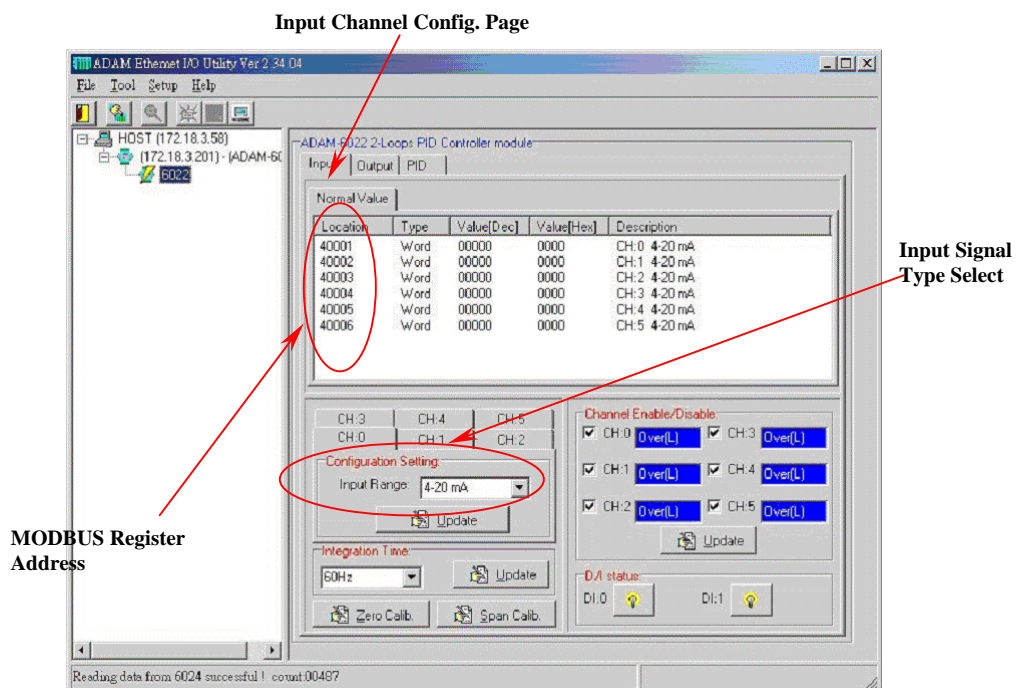

ADAM-6022 input channel configuration also support Zero and Span calibration function. Clicking the “Zero Calib” and “Span Calib” bottom to go to the calibration dialog block, user can set the initial zero value and span range then click the “Execute” bottom to proceed the channel calibration work. Please refer the following pictures for operation guideline.

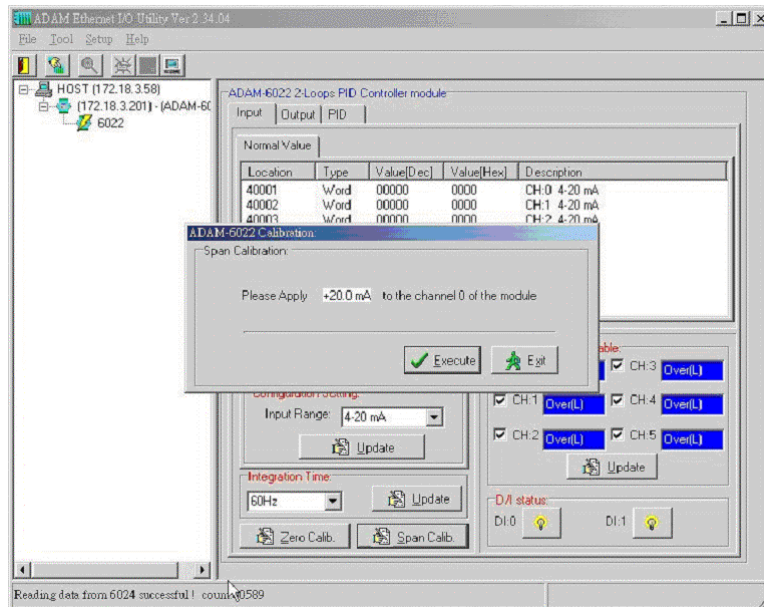
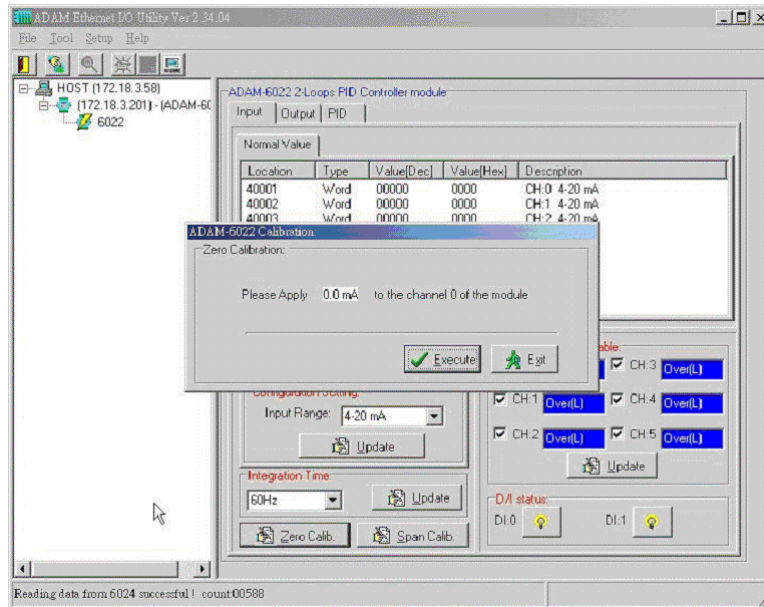

Output Channel Configuration Page :

For output channel configuration, there are two analog output channel in ADAM-6022. The output channel 0 is used as the control output for PID loop 0 and channel 1 is for PID loop 1 when PID loop function is enabled. The configuration for output channel is quite similar as input configuration. User can easily to finish the configuration with the friendly operating interface of ADAM-6022 utility software.

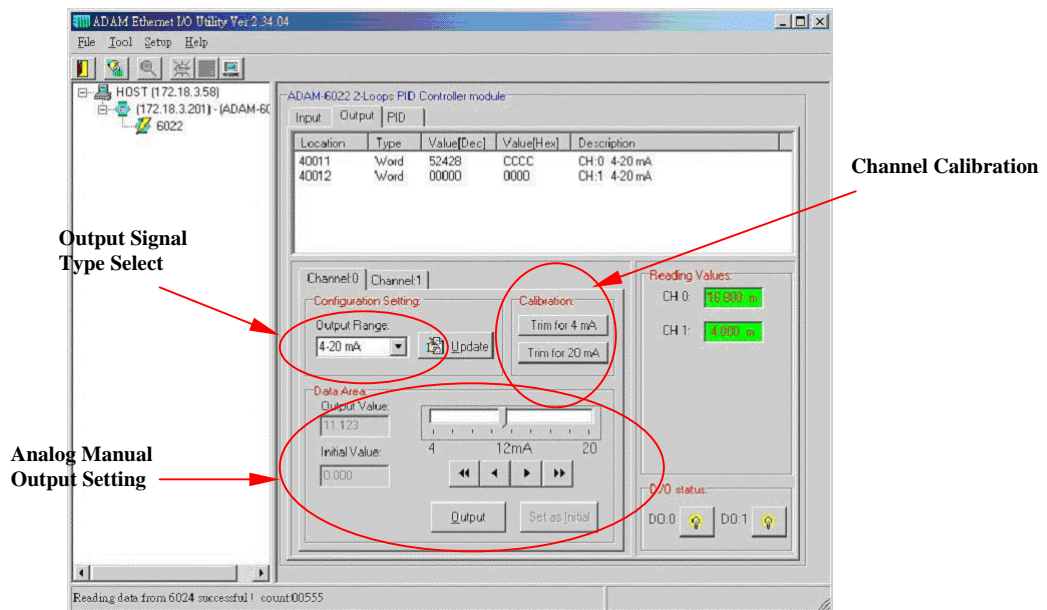

ADAM-6022 can be a pure universal I/O module when PID being set in Free mode. User can use “Data Area” to setup the analog output to send a specific value for such kind application. This function can also be controlled with MODBUS/TCP protocol through Ethernet network for HMI/SCADA application.

For calibrating the analog output channel, user can use external certificated signal measured device as calibrator then use the “Trim for 4mA” and “Trim for 20mA” calibrating function to fine tuning the channel output signal for calibration requirement.

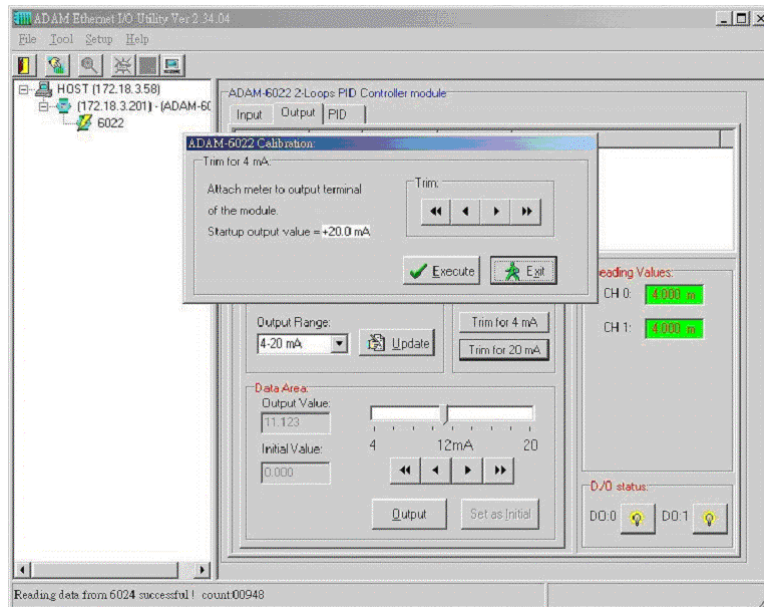
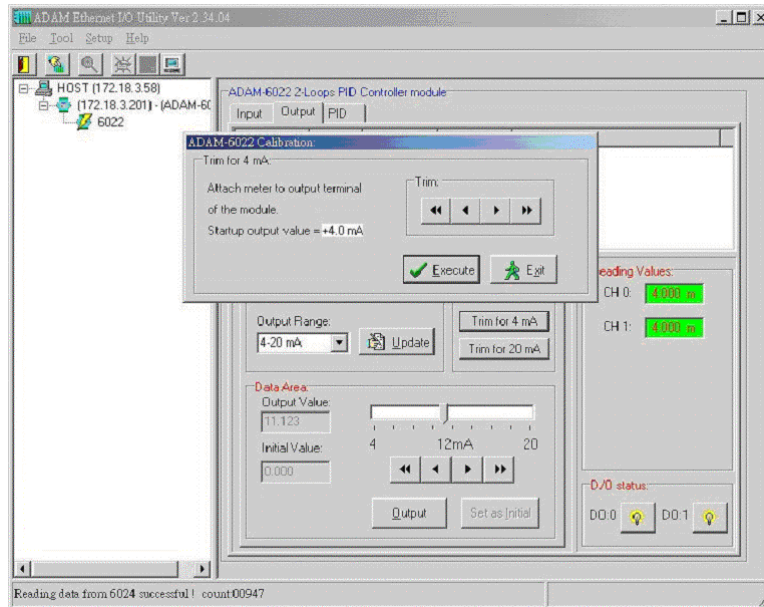



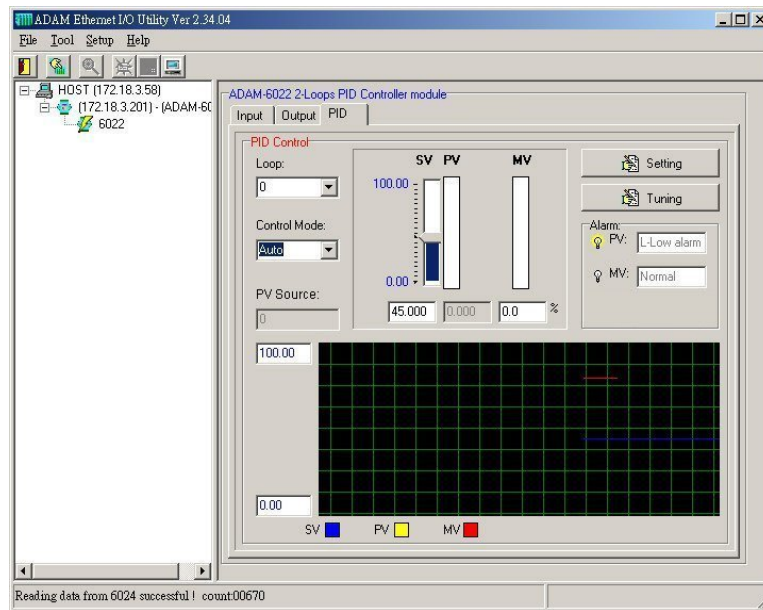

PID Loop Configuration

ADAM-6022 is designed as a stand alone PID controller. We offer a very convenient software tool for user to configure the PID controlled parameter. In this configuration page, there is a real time trend chart to show the values changing of SV, PV and MV. It is very helpful for user to monitor and diagnose the PID control situation.

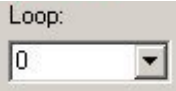

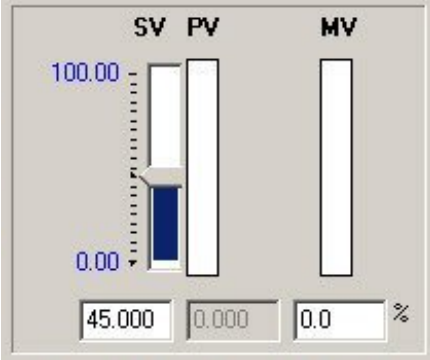
For the functionality of the bottom in PID configuration page, please refer the explanation of the following table.

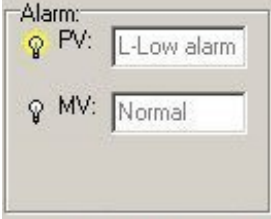

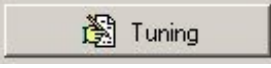
Bottom	Function
	PID loop number
	Control Mode Selection : Free : Stop PID Control Auto : PID Loop Automatically Manual : Manual Control
	Parameter Setting and Monitoring SV : Setpoint Value PV : Process Value MV : Controlled Output Value

	PV, MV Alarm Status
	PID Setting Bottom (go to PID setting page)
	PID Tuning Bottom (go to PID tuning page)

After finishing the setup work in configuration page, please click the setting bottom to go to the detail parameter setting screen.

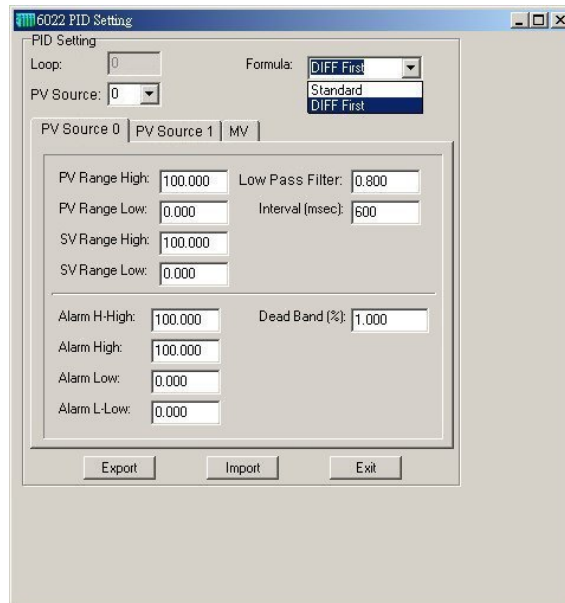
PV/SV Setting :

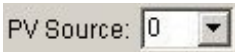

Bottom	Function
	Input channel for PV selection : For Loop 0 : PV set : 0 or 1 For Loop 1 : PV set : 3 or 4
	Formula Selection : Standard : Standard PID calculation DIFF First : Differentiation as first priority
SV Range High	SV high limit value
SV Range Low	SV low limit value
PV Range High	PV high limit value

PV Range Low	PV low limit value
Low Pass Filter	Low Pass Filter set value Low Pass Filter Calculation : MV Feedback = Reading MV x Filter Value + Previous MV x (1- Filter Value)
Interval (msec)	PID loop sensing time interval
Alarm H-High	SV & PV High High alarm setpoint
Alarm High	SV & PV High alarm setpoint
Alarm Low	SV & PV Low Low alarm setpoint
Alarm L-Low	SV & PV Low alarm setpoint

MV Setting

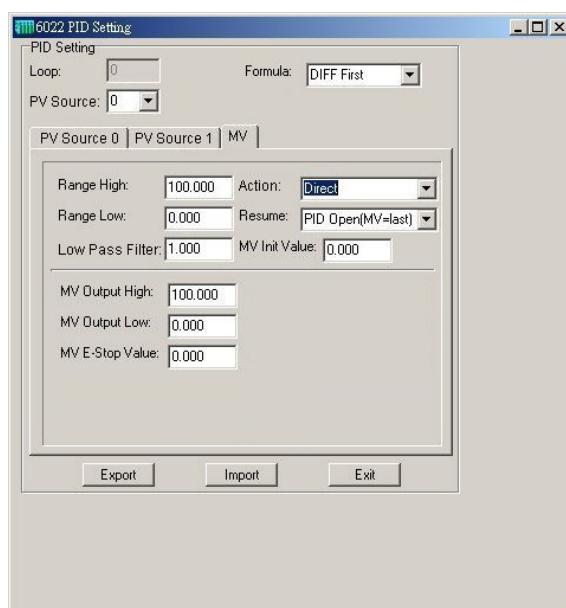

Bottom	Function
Action: Direct	Control Action Mode Setting : Direct : Direct (Heating) Action Reverse : Reverse (Cooling) Action
Resume: PID Open(MV=last)	PID Resume Status Setting
Range High	MV/FB high limit value
Range Low	MV/FB low limit value
Filter (0.0~1.0)	Filter set value
MV Init. Value	Setting MV initial value
MV Output High	MV output high limit
MV Output Low	MV output low limit

MV E-Stop Value	Setting MV frozen value while PID being emerged shutdown
-----------------	--

For PID parameter tuning, please refer the PID tuning page.

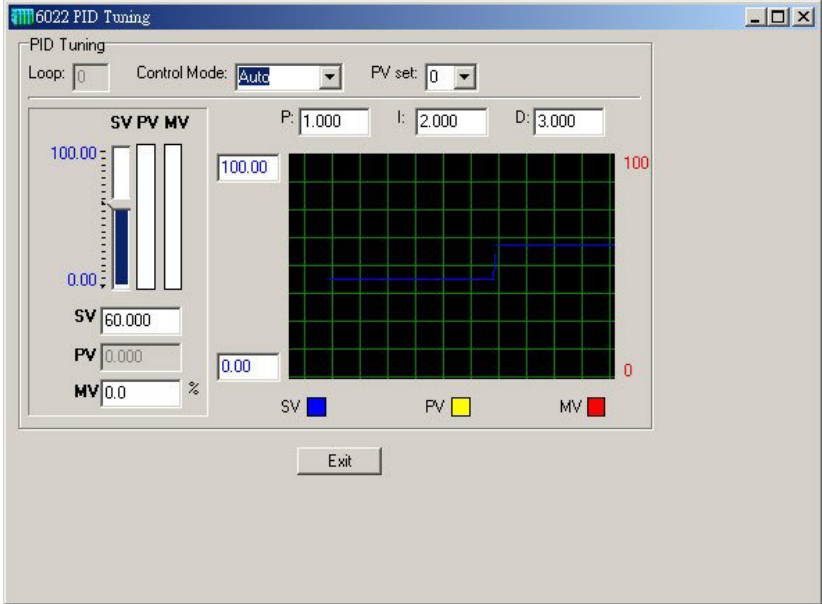

In this page, the P, I, D parameters can be adjusted to achieve the optimal control result. The real time trend chart provide a powerful tool for user to supervise the parameters adjustment result.

Appendix A

Command Set

ASCII command

Command	Description	Remarks
\$aaArr	Set the integration time for the module	!01: OK ?01: error
\$aaAccrr	Set the channel input range code	!01: OK ?01: error
\$aaB	Read the integration time for the module	!0150: 50ms(60Hz) !0160: 60ms(50Hz) ?01: error
\$aaBcc	Read the channel input range code	!01RR: RR is range code in HEX ?01: error
\$aaCcc	Read the channel output range code	!01RR: RR is range code in HEX ?01: error
\$aaCccrr	Set the channel output range code (after set, the output will be set to startup value)	!01: OK ?01: error
\$aaDcc	Read the channel startup output value	!01hhh: hhh is value in HEX (scaled, range from '000' to 'FFF') ?01: error
\$aaDcchhh	Set the channel startup output value cc: channel hhh: value (scaled, range from '000' to 'FFF')	!01: OK ?01: error
\$aaD	Set the EVA status to 0	!01: OK ?01: error
\$aaDA1	Ask module to open TCP port 5451 for ADuC 824 firmware download	!01: OK ?01: error
\$aaDA0	Ask module to close the download port.	!01: OK ?01: error
\$aaE0	Reset EVA to download mode (status = 0)	
\$aaF	Return the firmware version code from the specified ADAM-6000 module.	!01 V.vv: OK ?01: error
\$aaFMPV	Return the AD firmware version code from the specified ADAM-6000	!01 V.vv: OK ?01: error

	module.	
\$aaM	Return the module name from the specified module	!016022: OK ?01: error
\$aaRST	Reset password to "00000000"	!01: OK ?01: error
\$aaRcchhh	Set analog output without calibration (raw data)	!01: OK ?01: error
\$aa0	Calibrate the analog input module to correct the gain error	!01: OK ?01: error
\$aa1	Calibrate the analog input module to correct the offset error	!01: OK ?01: error
\$aa2cc	Read the MAX calibration value for analog output cc: channel (00~01)	!01hhh: OK ?01: error
\$aa2cchhh	Calibrate the analog output to correct the MAX value cc: channel (00~01)	!01: OK ?01: error
\$aa3cc	Read the MIN calibration value for analog output cc: channel (00~01)	!01hhh: OK ?01: error
\$aa3cchhh	Calibrate the analog output to correct the MIN error cc: channel (00~01)	!01: OK ?01: error
\$aa5mm	Enable/Disable multiplexing	!01: OK ?01: error
\$aa6	Asks a specified input module to return the status of all AI channels	!01mm: OK ?01: error
\$aa7	Asks a specified module to return the status of all DI channels	!01mm: OK ?01: error
#aa	Return the input values from all channels of the specified analog input module	>+xx.xxx+xx.xxx+xx.xxx+xx.xxx+xx.xxx: OK ?01: error
#aacc	Return the input value from the specified channel in the analog input module	>+xx.xxx: OK ?01: error
#aacdd	Set a single or all digital output channels.	>: OK ?01: error
#aacdd.ddd	Analog output to the specified channel cc: channel (00~01) dd.ddd: engineering units	>: OK ?01: error
#aaRcc	Read analog input without calibration (raw data)	>HHLL: OK ?01: error
@aaMAC	Read MAC address	!01mmmmmmmmmmmm

		?01: error
@aaMASK	Read subnet mask	!01mmmmmmmm ?01: error
@aaGW	Read default gateway	!01mmmmmmmm ?01: error
@aaDEVNAME	Read device name	!01ssssss... ?01: error
@aaDEVDESC	Read device description	!01:ssssss... ?01: error

Appendix B

Input range code mapping

Range code	Range value
0x07	4~20 mA
0x08	-10~10 V
0x0D	0~20 mA

Output range code mapping

Range code	Range value
0x00	0 ~ 20 mA
0x01	4 ~ 20 mA
0x02	0 ~ 10 V

Appendix C

PID Parameters Table for Modbus address :

Modbus Register Loop 0	Modbus Register Loop 1	Code	Read/Write	Decimal Place	Descriptions
41000	41256	Open/Close Mode	Read / Write	0	Enable/Disable PID loop function 0:Free mode -- no PID control, ADAM-6022 will be a pure I/O module 1:PID mode – enable PID loop function 2:Manual mode – manual control analog output
41002	41258	PID Mode	Read / Write	0	PID Mode Selection 0:Standard PID Calculation Mode 1:Differential First Mode
41004	41260	PV Mode	Read / Write	0	0:Select PV Source 1 as “PV” (PV-0 for Loop-0; PV-3 for Loop-1) 1:Select PV Source 2 as “PV” (PV-1 for Loop-0; PV-4 for Loop1)
41006	41262	Not used	N/A	N/A	Not used
41008	41264	PV Source 1 bare data	Read Only	3	PV Source 1 bare value (PV-0 for Loop-0; PV-3 for Loop-1)
41010	41266	PV Source 2 bare data	Read Only	3	PV Source 2 bare value (PV-1 for Loop-0; PV-4 for Loop1)

41012	41268	Manipulator value bare data	Read Only	3	MV bare value
41014	41270	Not used	N/A	N/A	Not used
41016	41272	DI On/Off	Read Only	0	DI for Emergency Shutdown
41018	41274	DO On/Off	Read Only	0	Alarm DO On
41020	41276	Set Point Value (PV Source 1)	Read / Write	3	SV (Set Point Value) for PV Source 1
41022	41278	Set Point Value (PV Source 2)	Read / Write	3	SV (Set Point Value) for PV Source 2
41024	41280	Range High (PV Source 1)	Read / Write	3	PV Source 1 Engineering Value Range High (Range High > Range Low)
41026	41282	Range Low (PV Source 1)	Read / Write	3	PV Source 1 Engineering Value Range Low (Range Low < Range High)
41028	41284	Range High (PV Source 2)	Read / Write	3	PV Source 2 Engineering Value Range High (Range High > Range Low)
41030	41286	Range Low (PV Source 2)	Read / Write	3	PV Source 2 Engineering Value Range Low (Range Low < Range High)
41032	41288	MV RH (Range High)	Read / Write	3	MV Engineering Value Range High (MV RH > MV RL)
41034	41290	MV RL (Range Low)	Read / Write	3	MV Engineering Value Range Low (MV RL < MV RH)
41036	41292	PV Source 1 engineering data	Read Only	3	PV Source 1 engineering data
41038	41294	PV Source 2 engineering data	Read Only	3	PV Source 2 engineering data
41040	41296	MV engineering data	Read / Write	3	MV engineering data can not only be automatically created by PID loop, but it also can be manual setup when PID loop set in "manual" mode. It will be translated as MV bare data AO output ◦ MV RL<MV engineering data<MV RH

Modbus Register Loop 0	Modbus Register Loop 1	Code	Read/Write	Decimal Place	Descriptions
41042	41298	Not used	N/A	N/A	Not used
41044	41300	PID PV value	Read Only	3	PID PV value
41046	41302	PID SV value	Read Only	3	PID SV value
41048	41304	Filter value (PV Source 1)	Read / Write	3	Low Pass Filter Value for PV source 1 $0 < (\text{Filter value}/1000) < 1.0$
41050	41306	Filter value (PV Source 2)	Read / Write	3	Low Pass Filter Value for PV source 2 $0 < (\text{Filter value}/1000) < 1.0$
41052	41308	Filter value (MV)	Read / Write	3	Low Pass Filter Value for MV $0 < (\text{Filter value}/1000) < 1.0$
41054	41310	PV Source 1 Range Code	Read Only	0	0: -10 ~ 10V 、 1: 0 - 20mA 、 2: 4 - 20mA
41056	41312	PV Source 2 Range Code	Read Only	0	0: -10 ~ 10V 、 1: 0 - 20mA 、 2: 4 - 20mA
41058	41314	Not used	N/A	N/A	Not used
41060	41316	MV Range Code	Read Only	0	0: 0 ~ 10V 、 1: 0 - 20mA 、 2: 4 - 20mA
41062	41318	PID KP (PV Source 1)	Read / Write	3	PID Proportional factor for PV Source 1 PID KP=(Input value/1000)
41064	41320	PID KI (PV Source 1)	Read / Write	3	PID Integrated factor for PV Source 1 PID KI=(Input value/1000)
41066	41322	PID KD (PV Source 1)	Read / Write	3	PID Differential factor for PV Source 1 PID KD=(Input value/1000)
41068	41324	PID KP (PV Source 2)	Read / Write	3	PID Proportional factor for PV Source 2 PID KP=(Input value/1000)
41070	41326	PID KI (PV Source 2)	Read / Write	3	PID Integrated factor for PV Source 2 PID KI=(Input value/1000)
41072	41328	PID KD (PV Source 2)	Read / Write	3	PID Differential factor for PV Source 2 PID KD=(Input value/1000)
41074	41330	PID KP (PID)	Read Only	3	PID Proportional factor for PID calculation
41076	41332	PID KI (PID)	Read Only	3	PID Integrated factor for PID calculation
41078	41334	PID KD (PID)	Read Only	3	PID Differential factor for PID calculation

Modbus Register Loop 0	Modbus Register Loop 1	Code	Read/Write	Decimal Place	Descriptions
41080	41336	Control loop period setting (msec) (PV Source 1)	Read / Write	0	<=0 : Loop empty >0 : Loop controlling
41082	41338	Control loop period setting (msec) (PV Source 2)	Read / Write	0	<=0 : Loop empty >0 : Loop controlling
41084	41340	Control loop period setting (msec) (PID)	Read Only	0	<=0 : Loop empty >0 : Loop controlling
41086	41342	Count down value of control loop period	Read Only	0	Counting value<=0 then calculating PID loop
41088	41344	Previous Loop Open/Close status	Read Only	0	Record the last Loop manual or auto mode for Loop Initial set °
41090	41346	NSEC	Read Only	0	Calculating the newest Loop interval as nsec
41092	41348	OLD NSEC	Read Only	0	Calculating the previous Loop interval as old nsec
41094	41350	Power recovery action setting	Read / Write	0	0: maintaining the previous MV output and keep PID open 1: Setting the previous MV output as initial value and keeping PID close 2: PID open, using MV initial value as MV output
41096	41352	MV Initial Value	Read / Write	3	MV initial value for power recovery action
41098	41354	Last DI State	Read Only	0	Previous Scan DI State (reference for control program)
41100	41356	Last DO State	Read Only	0	Previous Scan DO State (reference for control program)
41102	41358	Alarm HH Limit (PV Source 1)	Read / Write	3	Alarm High High Limit Value for PV Source 1 (< RH)
41104	41360	Alarm H Limit (PV Source 1)	Read / Write	3	Alarm High Limit Value for PV Source 1 (< RH && < Alarm HH)
41106	41362	Alarm LL Limit (PV Source 1)	Read / Write	3	Alarm Low Low Limit Value for PV Source 1 (> RL)

Modbus Register Loop 0	Modbus Register Loop 1	Code	Read/Write	Decimal Place	Descriptions
41108	41364	Alarm L limit (PV Source 1)	Read / Write	3	Alarm Low Limit Value for PV Source 1 (>RL && > Alarm LL)
41110	41366	Alarm Dead Band % (PV Source 1)	Read / Write	3	Dead band % for PV Source 1 $0 < (\text{Input Value}/1000)\% < 10\%$
41112	41368	Alarm Status (PV Source 1)	Read Only	0	Alarm Status for PV Source 1 0 : Normal 、 1:HH 、 2 : H 、 3:L 、 4:LL ◦
41114	41370	Alarm HH Limit (PV Source 2)	Read / Write	3	Alarm High High Limit Value for PV Source 2 (< RH)
41116	41372	Alarm H Limit (PV Source 2)	Read / Write	3	Alarm High Limit Value for PV Source 2 (< RH && < Alarm HH)
41118	41374	Alarm LL Limit (PV Source 2)	Read / Write	3	Alarm Low Low Limit Value for PV Source 2 (> RL)
41120	41376	Alarm L limit (PV Source 2)	Read / Write	3	Alarm Low Limit Value for PV Source 2 (>RL && > Alarm LL)
41122	41378	Alarm Dead Band % (PV Source 2)	Read / Write	3	Dead band % for PV Source 2 $0 < (\text{Input Value}/1000)\% < 10\%$
41124	41380	Alarm Status (PV Source 2)	Read Only	0	Alarm Status for PV Source 2 0 : Normal 、 1:HH 、 2 : H 、 3:L 、 4:LL ◦
41126	41382	Not used	N/A	N/A	Not used
41128	41384	Not used	N/A	N/A	Not used
41130	41386	Not used	N/A	N/A	Not used
41132	41388	Not used	N/A	N/A	Not used
41134	41390	Not used	N/A	N/A	Not used
41136	41392	Not used	N/A	N/A	Not used
41138	41394	MV Output High Limit	Read / Write	3	MV Output High Limit (<MV RH)
41140	41396	MV Output Low Limit	Read / Write	3	MV Output Low Limit (>MV RL)
41142	41398	MV Output Alarm Status	Read Only	0	MV Output Alarm Status 0 : Normal 、 1:H 、 2 : L
41144	41400	MV Emergency Value	Read / Write	3	MV output value while emergency shutdown DI being active
41146	41402	Open wire flag (PV Source 1)	Read Only	0	0 : Normal 1 : Open wire

					When the loop is in Open wire condition: <ul style="list-style-type: none"> ● The loop will switch to Manual mode. ● The MV will output the MV Emergency Value. ● The DO will switch to ON as an Alarm.
41148	41404	Open wire flag (PV Source 2)	Read Only	0	0 : Normal 1 : Open wire When the loop is in Open wire condition: <ul style="list-style-type: none"> ● The loop will switch to Manual mode. ● The MV will output the MV Emergency Value. ● The DO will switch to ON as an Alarm.
41150	41406	PID Direct/Reverse	Read / Write	0	0 : Direct Mode 1 : Reverse Mode
41152	41408	SV High Limit (PV Source 1)	Read/Write	3	SV High Limit value for PV Source 1
41154	41410	SV Low Limit (PV Source 1)	Read / Write	3	SV Low Limit value for PV Source 1
41156	41412	SV High Limit (PV Source 2)	Read / Write	3	SV High Limit value for PV Source 2
41158	41414	SV Low Limit (PV Source 2)	Read / Write	3	SV Low Limit value for PV Source 2

MODBUS functions address mapping

(1) Coils Address Mapping Table

Index(Address)	Remarks
1(0)	DI 0 status
2(1)	DI 1 status
3~16(2)~(15)	Reserved (for those reserved area, there will be no effect if you set it)
17(16)	DO 0 status
18(17)	DO 1 status
19~128(18)~(127)	Reserved

(2) Registers Address Mapping Table

Index(Address)	Remarks
1(0)	PV 0 value (PV Source 1 for PID loop-0)
2(1)	PV 1 value (PV Source 2 for PID loop-0)
3(2)	PV 2 value (Not for PID)
4(3)	PV 3 value (PV Source 1 for PID loop-1)
5(4)	PV 4 value (PV Source 2 for PID loop-1)
6(5)	PV 5 value (Not for PID)
7~10(6)~(9)	Reserved
11(10)	AO 0 value (MV for PID loop-0)
12(11)	AO 1 value (MV for PID loop-1)
13~20(12)~(19)	Reserved
21(20)	PV 0 status (0: normal; 1: over high; 2: over low; 3: invalid calibration)
22(21)	PV 1 status
23(22)	PV 2 status
24(23)	PV 3 status
25(24)	PV 4 status
26(25)	PV 5 status
27~64(26)~(63)	Reserved
---	Not support
1000~1511(999)~(1510)	<p>PID data area (total 512 registers)</p> <ul style="list-style-type: none"> ● Each PID data formed by two registers, for example: $\text{PID data}[0] = \text{reg}[1000] * 65536 + \text{reg}[1001]$ ● In the Appendix C, if the "Decimal Place" is 3, which means the actual value is the value we get, for example $\text{PID data}[10] = \text{reg}[1020] * 65536 + \text{reg}[1021]$, and then divided it by 10^3. In other word, the SV (Set Point Value) for PV Source 1 is $\text{PID data}[10]/1000$. ● PID loop-0 occupies from PID data[0] to PID [127]. ● PID loop-1 occupies from PID data[128] to PID [255]. ● For function 0x03, 0x04, you can read 100 registers at most one time ● For function 0x10, you must set even number of registers at a time. The starting address must be an even number as well. You can only set at most 100 registers at a time.
---	Not support
10000~(9999)~	MODBUS ASCII command data area